



Fully automatic espresso machine.

Fully automatic espresso machine 200 series.

44

Technical specifications.

45



CM 250 130

Aluminium-backed glass frontage
Width 60 cm

Included in the price

- 1 water filter cartridge
- 1 measuring spoon
- 1 assembly screws
- 1 milk container



Fully automatic espresso machine 200 series CM 250

- **Combinability with other appliances of the oven 200 series in the 45 cm high niche**
- **Continuous flow heater means no waiting time and constant brewing temperature**
- **Aroma brewing technology for a full aroma**
- **Single portion cleaning**
- **One-touch operation**
- **Personalisation function**
- **LED lighting**

Programmes

Espresso / 2 x Espresso.
Coffee / 2 x Coffee.
White coffee.
Latte macchiato.
Cappuccino.
Milk froth.
Warm milk.
Hot water.

Handling

LCD function display.
Clear text display in 15 languages.
Rotary knob and touch key operation.
Personalisation function, up to 6 beverages can be personalised and memorised.
3 cup size settings.
5 coffee strength levels from mild to extra strong.
3 coffee and hot water temperature levels.
4 grinding level settings.
Height-adjustable coffee dispenser up to 15 cm.
Automatic slide-out function at the push of a button.

Features

Grinding unit with ceramic discs.
Separate container for second ground coffee type.
Water pump with 19 bar pressure.
Continuous flow heater.
Aroma brewing technology.
Double shot function for strong beverages.
Double grinding and brewing cycles for two beverages.
Dispenser with integrated milk system.
Insulated milk container for up to 0.7 litres.
Integrated lighting with 3 LEDs.
Bean container for up to 1 kg.
Removable 2.5 litre water tank.
Electronic fill level control for water and coffee beans.
Electronic water filter exchange indicator.
Electronic fill level control for drip tray and container for coffee dregs.
Operation indicator.

Safety

Child lock.
Safety shut-off.

Cleaning

Single portion cleaning after every cup.
Fully automatic rinse programme when machine is turned on/off.
Automatic quick rinsing of milk system.
Automatic cleaning and descaling programme.
Removable brewing unit.
Coffee dregs container and drip tray dishwasher-safe.
Milk frother dishwasher-safe.

Planning notes

Ideal installation height 950 mm or higher.

When installing in a corner a side clearance of 200 mm is required.
The façade of the appliance extends 47 mm from the furniture cavity.
The cabinet must not have a rear panel behind the appliance.
Mount directly above 14 cm high warming drawer in 59 cm standard niche.

Connection

Total connected load 1.7 kW.
Connecting cable 1.5 m with 10 amp plug.
230-240V/50Hz

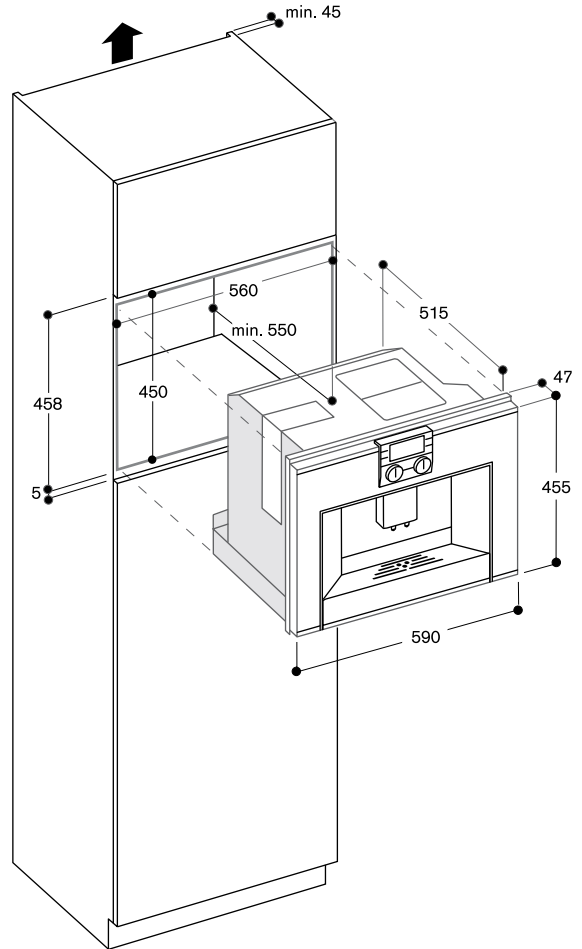

Installation in a corner

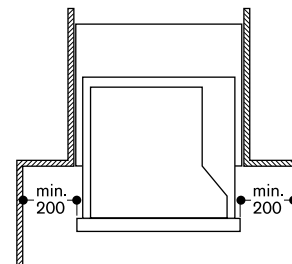



Appliance type		Fully automatic espresso machine
Series		200 series
Aluminium-backed glass frontage		CM 250 130
Dimensions		
Width	(cm)	60
Appliance dimensions W x H x D¹	(mm)	590 x 455 x 515
Façade extension from cavity	(mm)	47
Niche dimensions W x H x D	(mm)	560 x 450 x 550
Programms		
Beverages		Espresso / 2 x espresso Coffee / 2 x coffee White coffee, latte macchiato, cappuccino Milk froth Warm milk Hot water
Individual beverages	(No.)	6
Adjustable options		
- Cup sizes	(No.)	3
- Temperature levels	(No.)	3
- Coffee strength levels	(No.)	5
Handling		
LCD function display		•
Clear text display	(No. of languages)	15
Basic settings menu		•
Programmable functions		
- Water hardness	(No. of levels)	4
- Water filter		•
- Switch-off after	(h)	1 – 12
- Lighting scenarios	(No.)	7
- Variable beverage size		•
Features		
Grinding unit with ceramic discs		•
Continuous flow heater		•
Pump pressure	(bar)	19
Aroma brewing technology		•
Integrated milk system		•
Insulated milk container	(l)	0.7
Bean container	(g)	1000
Separate container for second ground coffee type		•
Grinding level control	(No. of levels)	4
Volume of adjustable brewing chamber	(g)	8 to 10
Double shot function		•
Removable water tank	(l)	2.5
Water filter cartridge for water tank		1
Single portion cleaning		•
Height adjustable coffee dispenser	(cm)	15
Integrated LED lighting		•
Child lock		•
Electronic water filter exchange indicator		•
Electronic fill level control for coffee beans and water		•
Electronic fill level control for drip tray and coffee dregs container		•
Cleaning		
Fully automatic rinse programme when switching on/off		•
Automatic quick rinsing of milk system		•
Automatic cleaning and descaling programme		•
Automatic cleaning programme		•
Automatic descaling programme		•
Removable brewing unit		•
Coffee dregs container and drip tray removable and dishwasher-safe		•
Milk frother removable and dishwasher-safe		•
Connection		
Total connected load	(kW)	1,7
Electrical supply cord	(cm)	150

- Standard. ¹ Appliance depth: the immersion depth of the appliance in the niche.

