

# NEFF D5855 UNDER-CUPBOARD RANGEHOOD IN DETAIL.

730mm UNDER-CUPBOARD RANGEHOOD

**D5855X0**

Stainless steel

730mm

3 speed plus intensive

Halogen lighting

Airflow up to 650m<sup>3</sup>/h

For ducted or recirculating extraction

► **FEATURES**

3 speeds plus intensive  
Twin motors  
2 x 20 Watt low energy halogen lamps  
2 metal grease filter cassettes

► **DESIGN**

730mm wide  
Under cupboard hood  
Slide control operation

► **TECHNICAL INFORMATION**

Maximum extraction rate 650 m<sup>3</sup>/hr  
Suitable for ducted extraction and recirculation  
Recirculating kit Z5155X0 (optional)  
Pipe outlet diameter (mm) 150 / 120  
Min. distance above electric hob (mm) 600  
Min. distance above gas hob (mm) 650  
Total connected load (W) 240

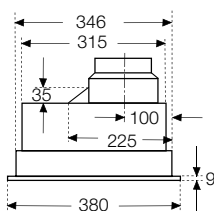
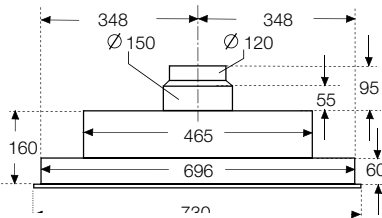
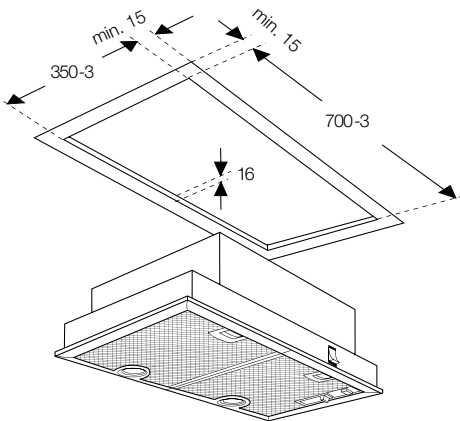

www.neff.com.au